

SERVICE BULLETIN SB1113
Original Instructions

Balcrank

Model 1120-015S

Table of Contents

Engineering Data and Temperature Limitations 1
 Explanation of Pump Nomenclature 2
 Performance Curve 3
 Dimensions 4
 Metric Dimensions 5
 Principle of Pump Operation..... 6
 Installation and Start-Up 6
 Air Supply 6
 Air Valve Lubrication..... 6
 Air Line Moisture..... 6
 Air Inlet and Priming 6
 Between Uses 6
 Installation Guide..... 7
 Troubleshooting 8
 Recycling 9
 Important Safety Information 9
 Composite Repair Parts Drawing 10
 Composite Repair Parts List & Available Service and Conversion Kits..... 10
 Air Distribution Valve Assembly Drawing and Parts List..... 11

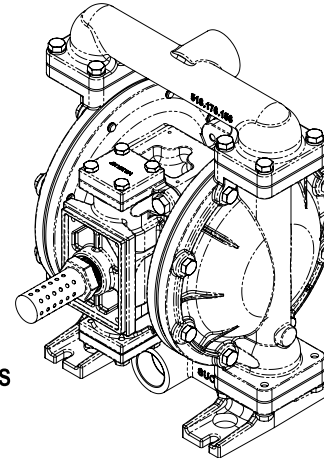

Air Distribution Valve Servicing..... 12
 Pilot Valve Servicing, Assembly Drawing & Parts List 13
 Diaphragm Service Drawing, Non-Overlay..... 14
 Diaphragm Servicing 15
 Overlay Diaphragm Servicing 15
 Actuator Plunger Servicing..... 16
 Check Valve Servicing..... 17
 Check Valve Drawing 17
 Muffler Drawing and Provision for Piping Air Exhaust 18
 Pumping Hazardous Liquids..... 18
 Converting Pump for Piping Exhaust Air 18
 Converted Exhaust Illustration..... 18
 Grounding The Pump 19
 Warranty 20

Balcrank

Model 1120-015S

Air-Operated Double Diaphragm Pump

ENGINEERING, PERFORMANCE
& CONSTRUCTION DATA

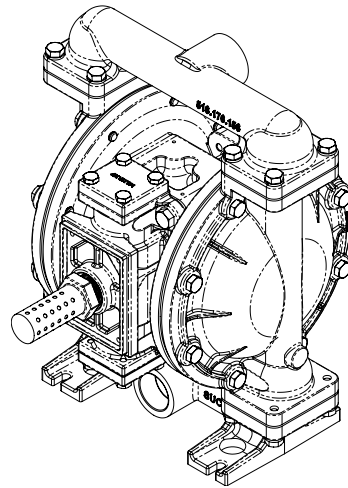

INTAKE/DISCHARGE PIPE SIZE 1" NPT(internal)	CAPACITY 0 to 45 gallons per minute (0 to 170 liters per minute)	AIR VALVE No-lube, no-stall design	SOLIDS-HANDLING Up to .25 in. (6mm)	HEADS UP TO 100 psi or 230.7 ft. of water (7 Kg/cm ² or 70 meters)	DISPLACEMENT/STROKE .11 Gallon / .42 liter
---	---	---	---	--	--

CAUTION! *Operating temperature limitations are as follows:*

Materials

	Operating Temperatures	
	Maximum	Minimum
Nitrile General purpose, oil-resistant. Shows good solvent, oil, water and hydraulic fluid resistance. Should not be used with highly polar solvents like acetone and MEK, ozone, chlorinated hydrocarbons and nitro hydrocarbons.	190°F 88°C	-10°F -23°C
Neoprene All purpose. Resistant to vegetable oil. Generally not affected by moderate chemicals, fats, greases and many oils and solvents. Generally attacked by strong oxidizing acids, ketones, esters, nitro hydrocarbons and chlorinated aromatic hydrocarbons.	170°F 77°C	-10°F -23°C
Virgin PTFE Chemically inert, virtually impervious. Very few chemicals are known to react chemically with PTFE: molten alkali metals, turbulent liquid or gaseous fluorine and a few fluoro-chemicals such as chlorine trifluoride or oxygen difluoride which readily liberate free fluorine at elevated temperatures.	212°F 100°C	-35°F -37°C
Polypropylene	150°F 65°C	-40°F -40°C
Polyethylene	180°F 82°C	-40°F -40°C

These pumps are designed to be powered only by compressed air.

Explanation of Pump Nomenclature

Model 1120-015S is UL79 listed for pumping: Diesel Fuel, No. 4 Fuel Oils (or lighter), Motor Oil, Kerosene, Aviation Fuel and Water

	<p>⚠ WARNING</p> <p><i>In the event of diaphragm rupture, pumped material may enter the air end of the pump, and be discharged into the atmosphere. If pumping a product which is hazardous or toxic, the air exhaust must be piped to an appropriate area for safe disposition.</i></p>
---	---

Performance Curve

Performance based on the following: elastomer fitted pump, flooded suction, water at ambient conditions.
 The use of other materials and varying hydraulic conditions may result in deviations in excess of 5%.

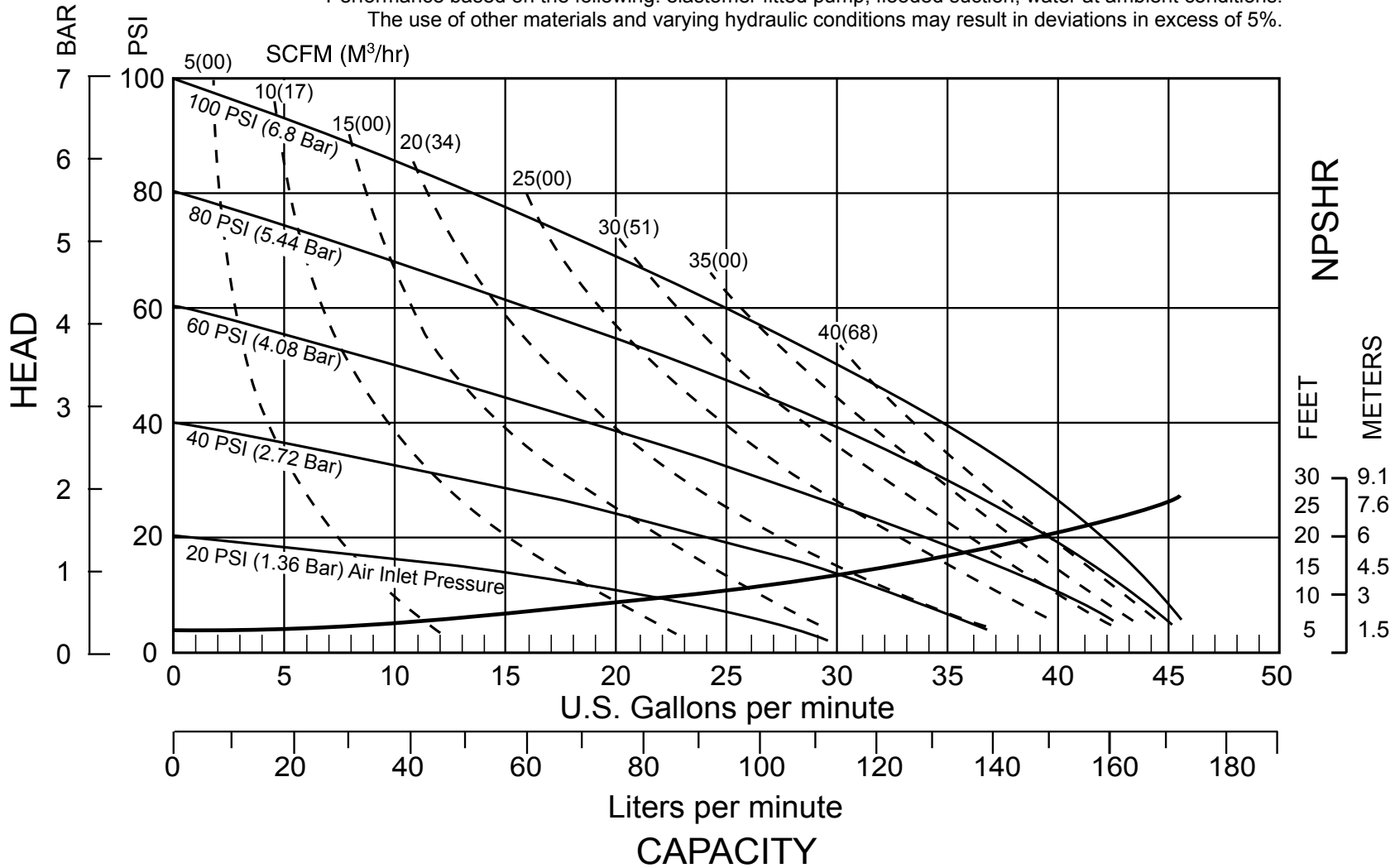

Dimensions:

Dimensions in Inches

Dimensional Tolerance: $\pm 1/8$ "

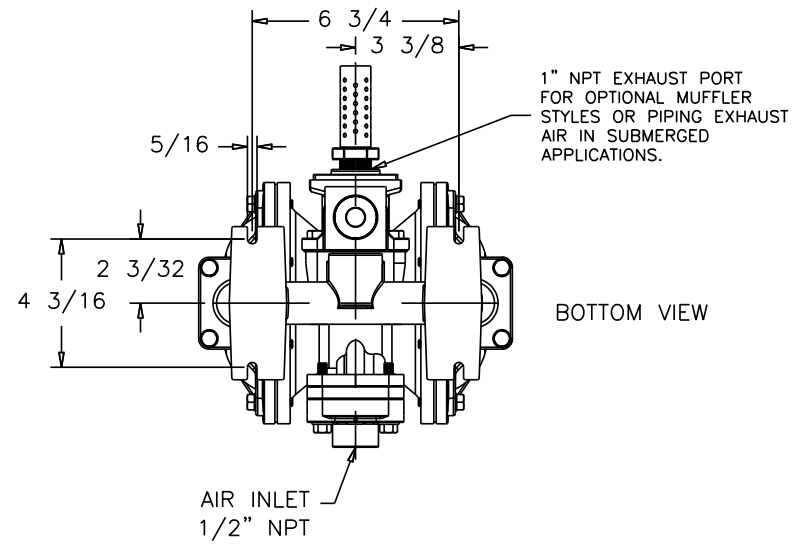
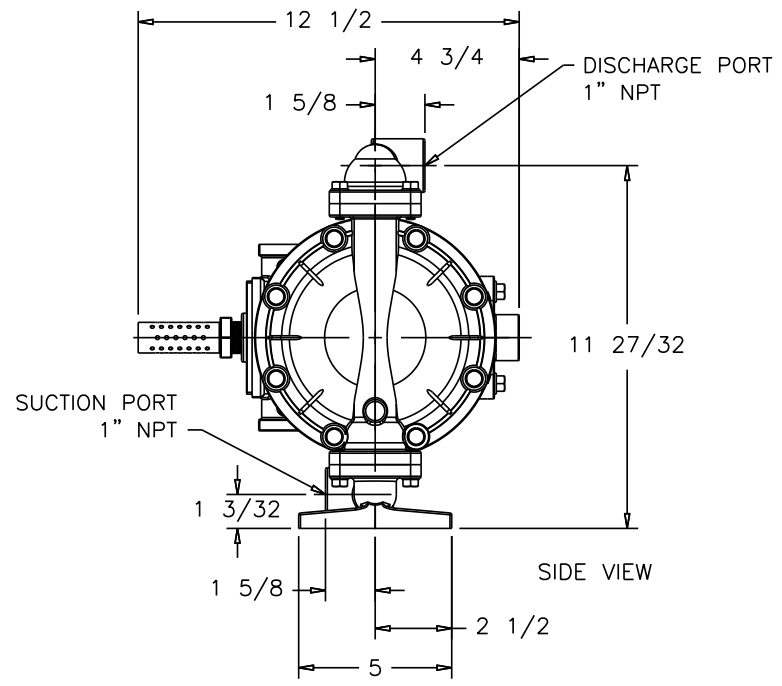
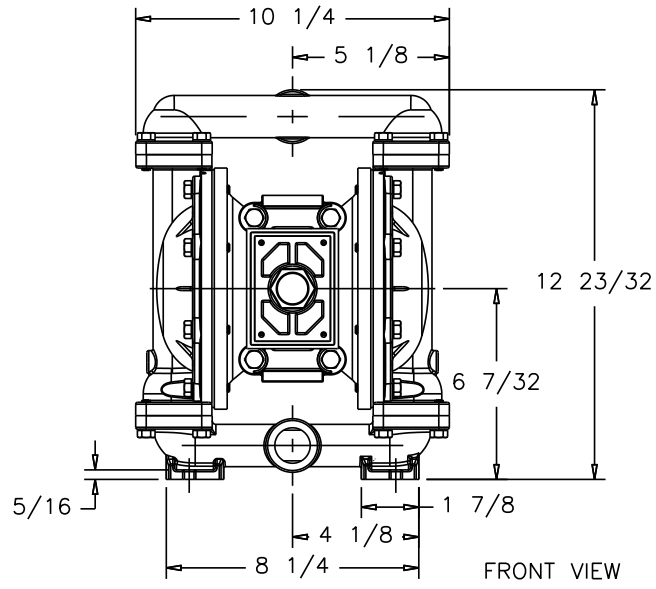

Metric Dimensions:

Dimensions in Millimeters
Dimensional Tolerance: $\pm 3\text{mm}$

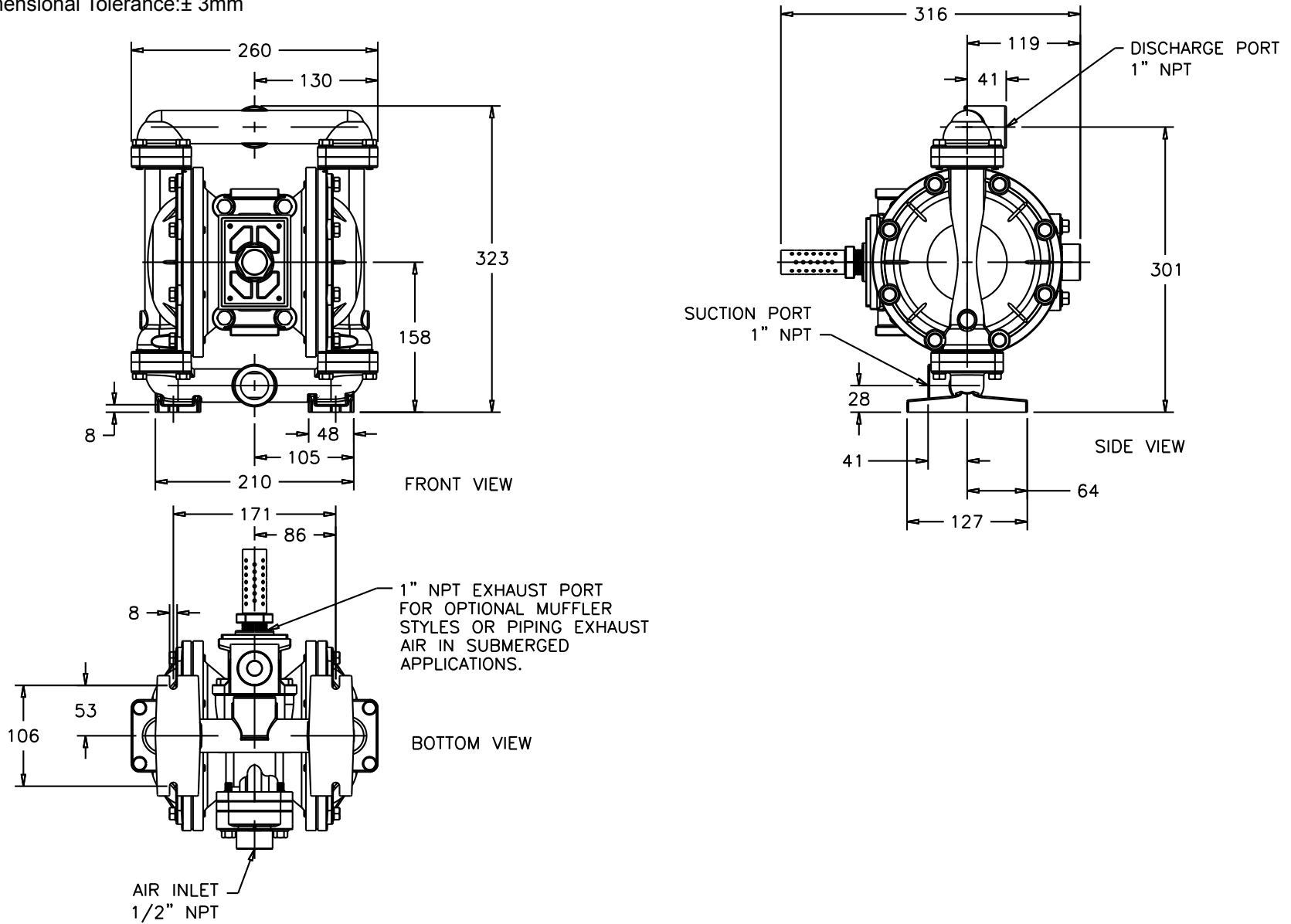

PRINCIPLE OF PUMP OPERATION

This ball type check valve pump is powered by compressed air and is a 1:1 ratio design. The inner side of one diaphragm chamber is alternately pressurized while simultaneously exhausting the other inner chamber. This causes the diaphragms, which are connected by a common rod secured by plates to the centers of the diaphragms, to move in a reciprocating action. (As one diaphragm performs the discharge stroke the other diaphragm is pulled to perform the suction stroke in the opposite chamber.) Air pressure is applied over the entire inner surface of the diaphragm while liquid is discharged from the opposite side of the diaphragm. The diaphragm operates in a balanced condition during the discharge stroke which allows the pump to be operated at discharge heads over 200 feet (61 meters) of water.

For maximum diaphragm life, keep the pump as close to the liquid being pumped as possible. Positive suction head in excess of 10 feet of liquid (3.048 meters) may require a back pressure regulating device to maximize diaphragm life.

Alternate pressurizing and exhausting of the diaphragm chamber is performed by an externally mounted, pilot operated, four way spool type air distribution valve. When the spool shifts to one end of the valve body, inlet pressure is applied to one diaphragm chamber and the other diaphragm chamber exhausts. When the spool shifts to the opposite end of the valve body, the pressure to the chambers is

reversed. The air distribution valve spool is moved by a internal pilot valve which alternately pressurizes one end of the air distribution valve spool while exhausting the other end. The pilot valve is shifted at each end of the diaphragm stroke when a actuator plunger is contacted by the diaphragm plate. This actuator plunger then pushes the end of the pilot valve spool into position to activate the air distribution valve.

The chambers are connected with manifolds with a suction and discharge check valve for each chamber, maintaining flow in one direction through the pump.

INSTALLATION AND START-UP

Locate the pump as close to the product being pumped as possible. Keep the suction line length and number of fittings to a minimum. Do not reduce the suction line diameter.

For installations of rigid piping, short sections of flexible conductive hose should be installed between the pump and the piping. The flexible conductive hose reduces vibration and strain to the pumping system. A surge suppressor is recommended to further reduce pulsation in flow.

AIR SUPPLY

Air supply pressure cannot exceed 100 psi (7 bar). Connect the pump air inlet to an air supply of sufficient capacity and pressure required for desired performance. When the air supply line is solid piping, use a short length of flexible conductive hose not less than 1/2" (13mm) in diameter between

the pump and the piping to reduce strain to the piping. The weight of the air supply line, regulators and filters must be supported by some means other than the air inlet cap. Failure to provide support for the piping may result in damage to the pump. A pressure regulating valve should be installed to insure air supply pressure does not exceed recommended limits.

AIR VALVE LUBRICATION

The air distribution valve and the pilot valve are designed to operate WITHOUT lubrication. This is the preferred mode of operation. There may be instances of personal preference or poor quality air supplies when lubrication of the compressed air supply is required. The pump air system will operate with properly lubricated compressed air supply. Proper lubrication requires the use of an air line lubricator set to deliver one drop of SAE 10 non-detergent oil for every 20 SCFM (9.4 liters/sec.) of air the pump consumes at the point of operation. Consult the pump's published Performance Curve to determine this.

AIR LINE MOISTURE

Water in the compressed air supply can create problems such as icing or freezing of the exhaust air, causing the pump to cycle erratically or stop operating. Water in the air supply can be reduced by using a point-of-use air dryer to supplement the user's air drying equipment. This device removes water from the compressed air supply and alleviates the icing or freezing problems.

AIR INLET AND PRIMING

To start the pump, open the air valve approximately 1/2" to 3/4" turn. After the pump primes, the air valve can be opened to increase air flow as desired. If opening the valve increases cycling rate, but does not increase the rate of flow, cavitation has occurred. The valve should be closed slightly to obtain the most efficient air flow to pump flow ratio.

BETWEEN USES

When the pump is used for materials that tend to settle out or solidify when not in motion, the pump should be flushed after each use to prevent damage. (Product remaining in the pump between uses could dry out or settle out. This could cause problems with the diaphragms and check valves at restart.) In freezing temperatures the pump must be completely drained between uses in all cases.

INSTALLATION GUIDE

Top Discharge Ball Valve Pump

⚠ CAUTION

Use a gasoline-resistant pipe compound to make pipe joints tight.

Pump shall be installed in accordance to Flammable and Combustible Liquids Code, NFPA 30 or the Automotive and Marine Service Station Code, NFPA 30A, as appropriate to the intended use of the pump.



⚠ CAUTION
The air exhaust should be piped to an area for safe disposition of the product being pumped, in the event of a diaphragm failure.



⚠ WARNING
To maintain conductivity, do not paint the pump, or if painted, use a conductive paint or coating.

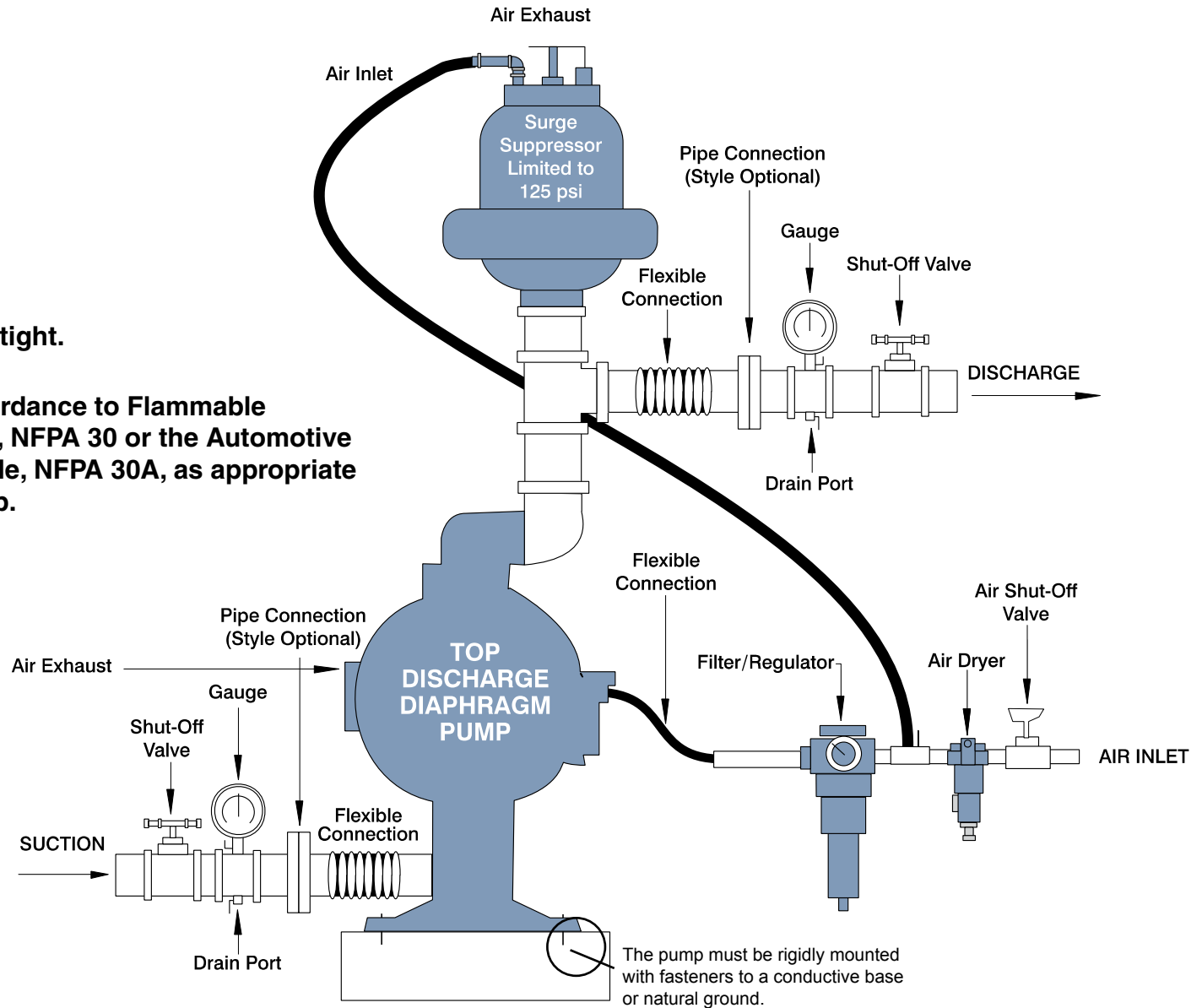

TROUBLESHOOTING

Possible Symptoms:

- Pump will not cycle.
- Pump cycles, but produces no flow.
- Pump cycles, but flow rate is unsatisfactory.
- Pump cycle seems unbalanced.
- Pump cycle seems to produce excessive vibration.

What to Check: Excessive suction lift in system.

Corrective Action: For lifts exceeding 20 feet (6 meters), filling the pumping chambers with liquid will prime the pump in most cases.

What to Check: Excessive flooded suction in system.

Corrective Action: For flooded conditions exceeding 10 feet (3 meters) of liquid, install a back pressure device.

What to Check: System head exceeds air supply pressure.

Corrective Action: Increase the inlet air pressure to the pump. Most diaphragm pumps are designed for 1:1 pressure ratio at zero flow.

What to Check: Air supply pressure or volume exceeds system head.

Corrective Action: Decrease inlet air pressure and volume to the pump as calculated on the published PERFORMANCE CURVE. Pump is cavitating the fluid by fast cycling.

What to Check: Undersized suction line.

Corrective Action: Meet or exceed pump connection recommendations shown on the DIMENSIONAL DRAWING.

What to Check: Restricted or undersized air line.

Corrective Action: Install a larger air line and connection. Refer to air inlet recommendations shown in your pump's SERVICE MANUAL.

What to Check: Check ESADS, the Externally Serviceable Air Distribution System of the pump.

Corrective Action: Disassemble and inspect the main air distribution valve, pilot valve and pilot valve actuators. Refer to the parts drawing and air valve section of the SERVICE MANUAL. Check for clogged discharge or closed valve before reassembly.

What to Check: Rigid pipe connections to pump.

Corrective Action: Install flexible connectors and a surge suppressor.

What to Check: Blocked air exhaust muffler.

Corrective Action: Remove muffler screen, clean or de-ice and reinstall. Refer to the Air Exhaust section of your pump SERVICE MANUAL.

What to Check: Pumped fluid in air exhaust muffler.

Corrective Action: Disassemble pump chambers. Inspect for diaphragm rupture or loose diaphragm plate assembly. Refer to the Diaphragm Replacement section of your pump SERVICE MANUAL.

What to Check: Suction side air leakage or air in product.

Corrective Action: Visually inspect all suction side gaskets and pipe connections.

What to Check: Obstructed check valve.

Corrective Action: Disassemble the wet end of the pump and manually dislodge obstruction in the check valve pocket. Refer to the Check Valve section of the pump SERVICE MANUAL for disassembly instructions.

What to Check: Worn or misaligned check valve or check valve seat.

Corrective Action: Inspect check valves and seats for wear and proper seating. Replace if necessary. Refer to Check Valve section of the pump SERVICE MANUAL for disassembly instructions.

What to Check: Blocked suction line.

Corrective Action: Remove or flush obstruction. Check and clear all suction screens and strainers.

What to Check: Blocked discharge line.

Corrective Action: Check for obstruction or closed discharge line valves.

What to Check: Blocked pumping chamber.

Corrective Action: Disassemble and inspect the wetted chambers of the pump. Remove or flush any obstructions. Refer to the pump SERVICE MANUAL for disassembly instructions.

What to Check: Entrained air or vapor lock in one or both pumping chambers.

Corrective Action: Purge chambers through tapped chamber vent plugs. PURGING THE CHAMBERS OF AIR CAN BE DANGEROUS! Contact your Technical Services Department before performing this procedure. Any model with top-ported discharge will reduce or eliminate problems with entrained air.

If your pump continues to perform below your expectations, contact your factory Technical Services Group for a service evaluation.

RECYCLING

Many components of Balcrank Metallic AODD pumps are made of recyclable materials. We encourage pump users to recycle worn out parts and pumps whenever possible, after any hazardous pumped fluids are thoroughly flushed.



Underwriters Laboratories, Inc., an Internationally recognized independent organization for testing products to ensure public safety.

IMPORTANT SAFETY INFORMATION



IMPORTANT

Read these safety warnings and instructions in this manual completely, before installation and start-up of the pump. It is the responsibility of the purchaser to retain this manual for reference. Failure to comply with the recommendations stated in this manual will damage the pump, and void factory warranty.



CAUTION

Before pump operation, inspect all gasketed fasteners for looseness caused by gasket creep. Retorque loose fasteners to prevent leakage. Follow recommended torques stated in this manual.



WARNING

Before maintenance or repair, shut off the compressed air line, bleed the pressure, and disconnect the air line from the pump. The discharge line may be pressurized and must be bled of its pressure.



WARNING

In the event of diaphragm rupture, pumped material may enter the air end of the pump, and be discharged into the atmosphere. If pumping a product which is hazardous or toxic, the air exhaust must be piped to an appropriate area for safe disposition.



WARNING

Take action to prevent static sparking. Fire or explosion can result, especially when handling flammable liquids. The pump, piping, valves, containers or other miscellaneous equipment must be grounded.



WARNING

This pump is pressurized internally with air pressure during operation. Always make certain that all bolting is in good condition and that all of the correct bolting is reinstalled during assembly.

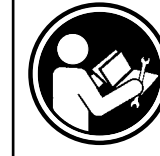

WARNING

When used for toxic or aggressive fluids, the pump should always be flushed clean prior to disassembly.



WARNING

Before doing any maintenance on the pump, be certain all pressure is completely vented from the pump, suction, discharge, piping, and all other openings and connections. Be certain the air supply is locked out or made non-operational, so that it cannot be started while work is being done on the pump. Be certain that approved eye protection and protective clothing are worn all times in the vicinity of the pump. Failure to follow these recommendations may result in serious injury or death.



WARNING

Airborne particles and loud noise hazards. Wear ear and eye protection.



WARNING

Do not smoke near the pump or use the pump near an open flame. Fire or explosion could result.



WARNING

Do not use this pump with potable water or fluids for human consumption.

Composite Repair Parts List

ITEM	DESCRIPTION	QTY
1	Air Valve Assembly	1
2	Ball, Check Nitrile	4
3	Bushing	2
4	Pilot Valve Assembly	1
5	Intermediate	1
6	Bumper	2
7	Bushing	2
8	Cap, Air Inlet Assembly	1
9	Capscrew, Hex Hd 5/16-18 X 1.00	16
10	Capscrew, Hex Hd 5/16-18 X 1.25	16
11	Capscrew, Hex Hd 5/16-18 X 1.75	4
12	Capscrew, Hex Hd 3/8-16 X 1.00	4
13	Chamber, Outer	2
14	Diaphragm Nitrile	2
16	Gasket, Air Valve	1
17	Gasket, Pilot Valve	1
18	Gasket, Air Inlet	1
19	Manifold, Suction	1
20	Manifold, Discharge	1
21	O-Ring	2
23	Plate, Inner Diaphragm	2
24	Plate, Outer Diaphragm Assembly	2
25	Pin, Actuator	2
26	Ring, Retaining	2
27	Rod, Diaphragm	1
28	Seal, U-Cup	2
29	Seat, Check Ball PTFE	4
30	Lockwasher	16
31	Flatwasher	4
32	Ground Strap	1
33	Metal Muffler	1

Composite Repair Parts Drawing

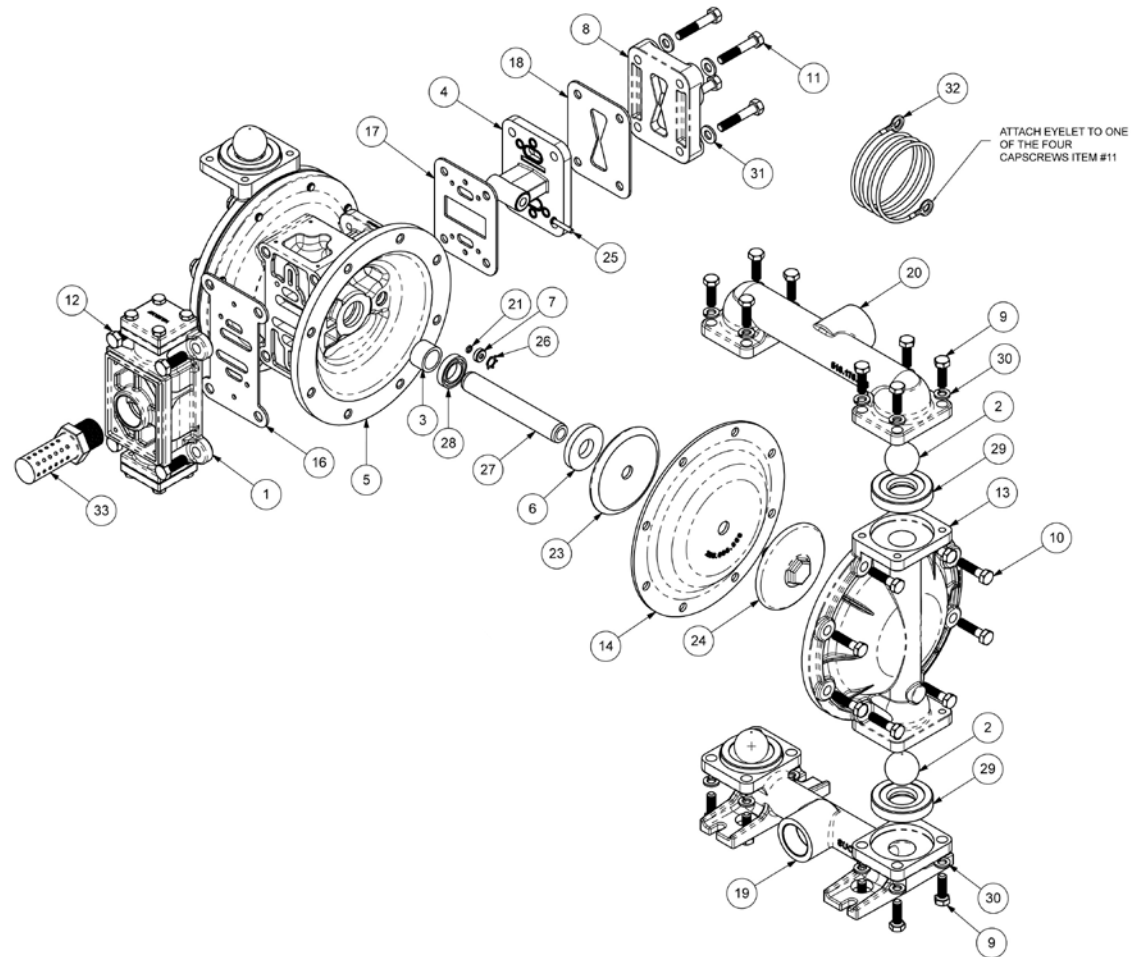

Air End Kit

832973 Seals, O-Rings, Gaskets, Retaining Rings, Air Valve Assembly and Pilot Valve Assembly

Wet End Kit

832974 Nitrile Diaphragms, Nitrile Check Balls and PTFE Check Valve Seats

Air End Seal Kit

833103 O-rings, Gaskets, Retaining Rings, Bumpers, Bushings, and Seals

Air Valve Assembly Drawing, Parts List

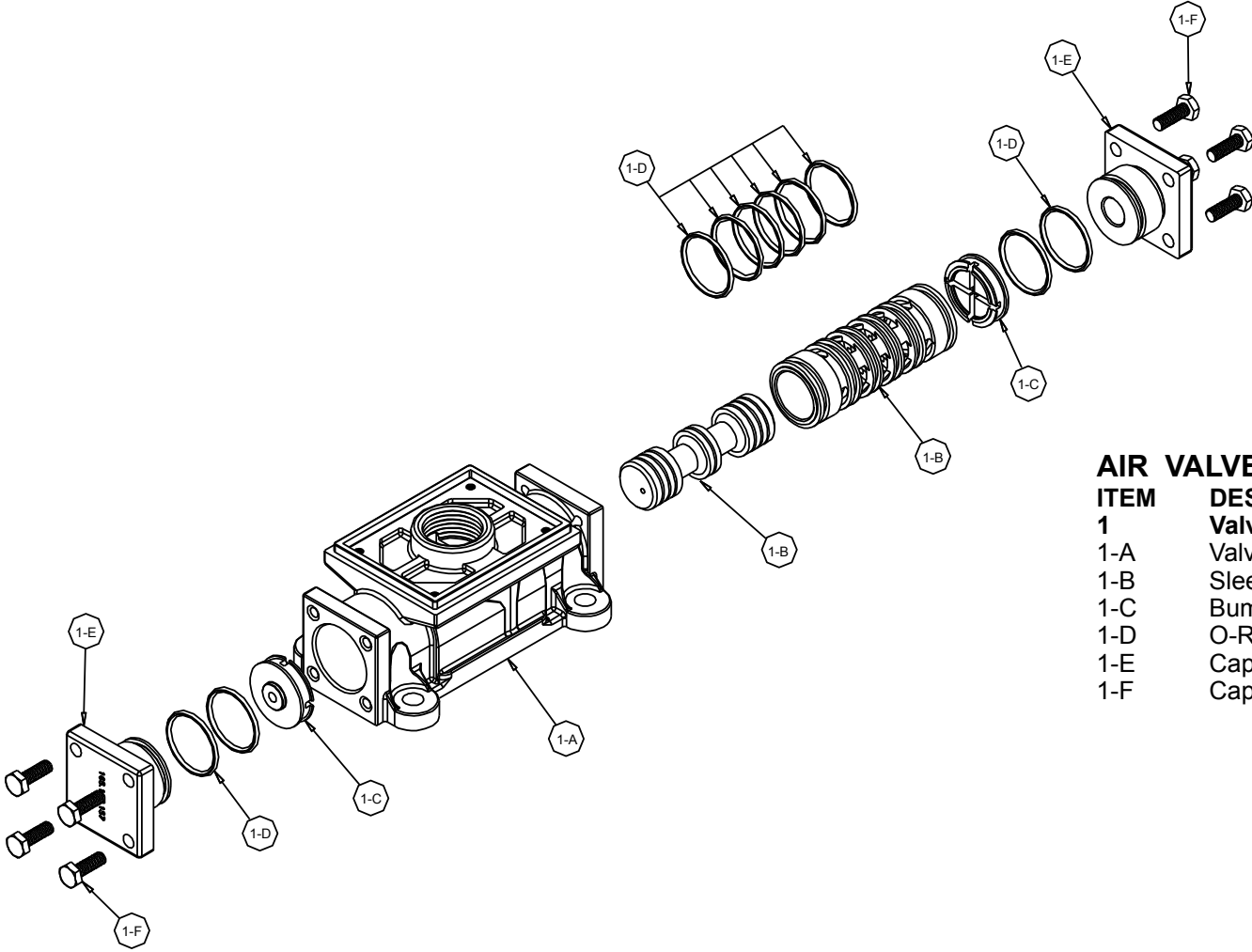

AIR VALVE ASSEMBLY PARTS LIST

ITEM	DESCRIPTION	QTY
1	Valve Assembly	1
1-A	Valve Body	1
1-B	Sleeve and Spool Set	1
1-C	Bumper	2
1-D	O-Ring	10
1-E	Cap, End	2
1-F	Capscrew	8

AIR DISTRIBUTION VALVE SERVICING

To service the air valve first shut off the compressed air, bleed pressure from the pump, and disconnect the air supply line from the pump.

STEP #1: See COMPOSITE REPAIR PARTS DRAWING.

Using a 9/16" wrench or socket, remove the four hex head capscrews (item 10). Remove the air valve assembly from the pump.

Remove and inspect gasket (item 16) for cracks or damage. Replace gasket if needed.

STEP #2: Disassembly of the air valve.

Using a 7/16" wrench or socket, remove the eight hex capscrews (item 1-F) that fasten the end caps to the valve body.

Next remove the two end caps (items 1-E). Inspect two o-rings (items 1-D) on each end cap for damage or wear. Replace the o-rings as needed.

Remove the bumpers (items 1-C). Inspect the bumpers for damage or wear.

Remove the spool (part of item 1-A) from the sleeve. Be careful not to scratch or damage the outer diameter of the spool. Wipe spool with a soft cloth and inspect for scratches or wear.

Inspect the inner diameter of the sleeve (part of item 1-A) for dirt, scratches, or other contaminants. Remove the sleeve if needed and replace with a new sleeve and spool set (item 1-A).

STEP #3: Reassembly of the air valve.

Install one bumper (item 1-C) and one end cap (item 1-E) with two o-rings (item 1-D) and fasten with four hex capscrews (items 1-F) to the valve body (items 1-A).

Remove the new sleeve and spool set (item 1-A) from the plastic bag. Carefully remove the spool from the sleeve. Install the six o-rings (item 1-G) into the six grooves on the sleeve. Apply a light coating of grease to the o-rings before installing the sleeve into the valve body (item 1-B), align the slots in the sleeve with the slots in the valve body. Insert the spool into the sleeve. Be careful not to scratch or damage the spool during installation. Push the spool in until it touches the bumper on the opposite end.

Install the remaining bumper, end cap (with o-rings), and fasten with the remaining hex capscrews.

Fasten the air valve assembly (item 1) and gasket (item 16) to the pump.

Connect the compressed air line to the pump. The pump is now ready for operation.



! IMPORTANT

Read these instructions completely, before installation and start-up. It is the responsibility of the purchaser to retain this manual for reference. Failure to comply with the recommendations stated in this manual will damage the pump, and void factory warranty.

Pilot Valve Servicing, Assembly Drawing & Parts List

PILOT VALVE ASSEMBLY PARTS LIST

ITEM	DESCRIPTION	QTY
4	Pilot Valve Assembly	1
4-A	Valve Body	1
4-B	Sleeve (With O-rings)	1
4-C	O-ring (Sleeve)	6
4-D	Spool (With O-rings)	1
4-E	O-ring (Spool)	3
4-F	Retaining Ring	1

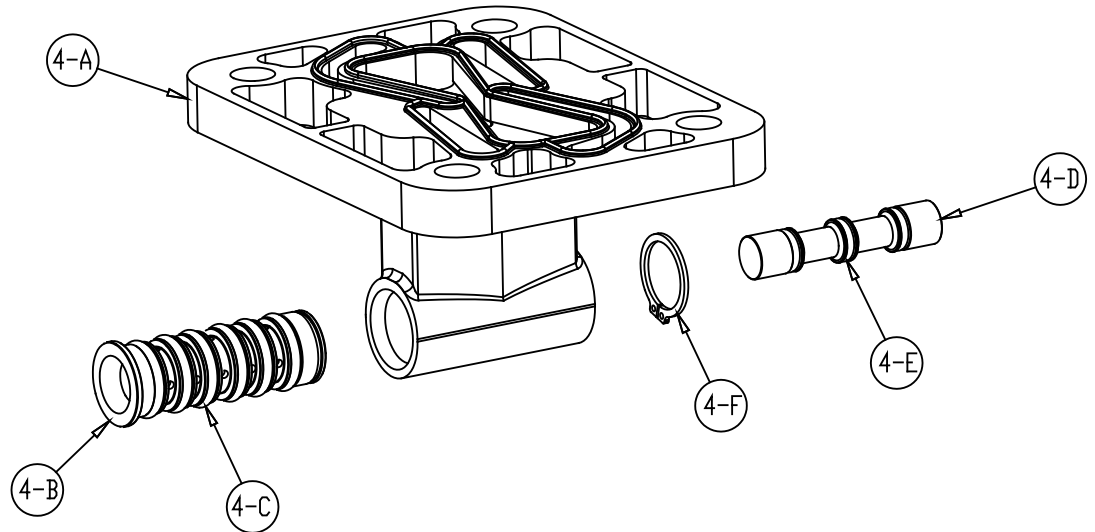

PILOT VALVE SERVICING

To service the pilot valve first shut off the compressed air supply, bleed the pressure from the pump, and disconnect the air supply line from the pump.

STEP #1: See pump assembly drawing.

Using a 1/2" wrench or socket, remove the four capscrews (item 12). Remove the air inlet cap (item 8) and air inlet gasket (item 18). The pilot valve assembly (item 4) can now be removed for inspection and service.

STEP #2: Disassembly of the pilot valve.

Remove the pilot valve spool (item 4-D). Wipe clean and inspect spool and o-rings for dirt, cuts or wear. Replace the o-rings and spool if necessary.

Remove the retaining ring (item 4-F) from the end of the sleeve (item 4-B) and remove the sleeve from the valve body (item 4-A). Wipe clean and inspect sleeve and o-rings for dirt, cuts or wear. Replace the o-rings and sleeve if necessary.

STEP #3: Re-assembly of the pilot valve.

Generously lubricate outside diameter of the sleeve and o-rings. Then carefully insert sleeve into valve body. Take CAUTION when inserting sleeve, not to shear any o-rings. Install retaining ring to sleeve. Generously lubricate outside diameter of spool and o-rings. Then carefully insert spool into sleeve. Take CAUTION when inserting spool, not to shear any o-rings. Use BP-LS-EP-2 multipurpose grease, or equivalent.

STEP #4: Re-install the pilot valve assembly into the intermediate.

Be careful to align the ends of the pilot valve stem between the plunger pins when inserting the pilot valve into the cavity of the intermediate.

Re-install the gasket, air inlet cap and capscrews. Connect the air supply to the pump. The pump is now ready for operation.

Diaphragm Service Drawing

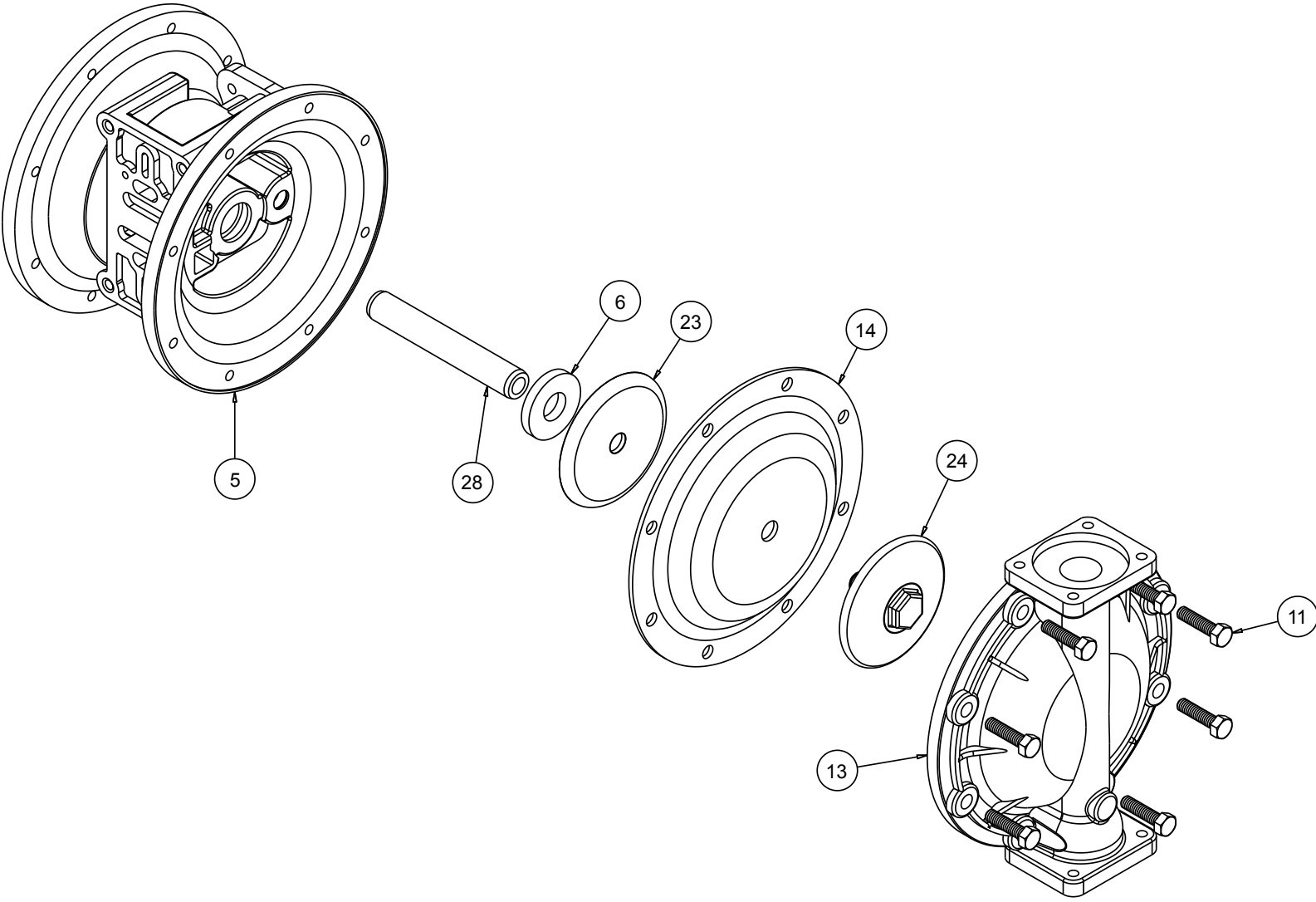

DIAPHRAGM SERVICING

To service the diaphragms first shut off the suction, then shut off the discharge lines to the pump. Shut off the compressed air supply, bleed the pressure from the pump and disconnect the air supply line from the pump. Drain any remaining liquid from the pump.

Step #1: See the pump assembly drawing and the diaphragm servicing illustration.

Using a 1/2" wrench or socket, remove the 16 capscrews (item 9) that fasten the manifolds (items 19 & 20) to the outer chambers (item 13).

Step #2: Removing outer chambers.

Using a 1/2" wrench or socket, remove the 16 capscrews (item 11), that fasten the outer chambers (item 13), diaphragms (item 14) and intermediate (item 5) together.

Step #3: Removing the diaphragms and diaphragm plates.

Use a 7/8" wrench or six point socket to remove the outer diaphragm plate assemblies (item 24), diaphragms (item 14) and inner diaphragm plates (item 23) from the diaphragm rod (item 28) by turning counterclockwise. Inspect the diaphragm for cuts, punctures, abrasive wear or chemical attack. Replace the diaphragms if necessary. **DO NOT USE A WRENCH ON THE DIAPHRAGM ROD. FLAWS ON THE SURFACE MAY DAMAGE BEARINGS AND SEALS.**

Step #4: Assembling the diaphragm and diaphragm plates to the diaphragm rod.

Push the threaded stud of one outer diaphragm plate assembly through the center of one diaphragm and through one inner diaphragm plate. Install the diaphragm with the natural bulge facing away from the diaphragm rod and make sure the radius on the inner diaphragm plate is towards the diaphragm, as indicated on the diaphragm servicing illustration. Thread the assembly onto the diaphragm rod, leaving loose.

Step #5: Installing the diaphragm and rod assembly to the pump.

Make sure the bumper (item 6) is installed over the diaphragm rod. Insert rod into pump.

On the opposite side of the pump, pull the diaphragm rod out as far as possible. Make sure the second bumper is installed over the diaphragm rod.

Push the threaded stud of the other outer diaphragm plate assembly through the center of the other diaphragm and through the other inner diaphragm plate. Make sure the radius on the inner diaphragm plate is towards the diaphragm. Thread the assembly onto the diaphragm rod. Use a 7/8" wrench or socket to hold one outer diaphragm plate. Then, use a torque wrench to tighten the other outer diaphragm plate to the diaphragm rod to 350 in. lbs. (39.5 Newton meters).

Align one diaphragm with the intermediate and install the outer chamber to the pump using the 8 capscrews. Tighten the opposite diaphragm plate until the holes in the diaphragm align with the holes in the intermediate. Then, install the other outer chamber using the 8 capscrews.

Step #6: Reinstall the manifolds to the pump using the 16 capscrews.

The pump is now ready to be reinstalled, connected and returned to operation.

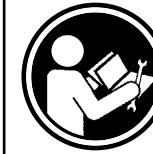

! IMPORTANT

Read these instructions completely, before installation and start-up. It is the responsibility of the purchaser to retain

this manual for reference. Failure to comply with the recommendations stated in this manual will damage the pump, and void factory warranty.

ACTUATOR PLUNGER SERVICING

To service the actuator plunger first shut off the compressed air supply, bleed the pressure from the pump, and disconnect the air supply line from the pump.

Step #1: See PUMP ASSEMBLY DRAWING.

Using a 1/2" wrench or socket, remove the four capscrews (items 11). Remove the air inlet cap (item 8) and air inlet gasket (item 18). The pilot valve assembly (item 4) can now be removed.

Step #2: Inspect the actuator plungers.

See ILLUSTRATION AT RIGHT.

The actuator plungers (items 25) can be reached through the pilot valve cavity in the intermediate assembly (item 5).

Remove the plungers (item 25) from the bushings (item 7) in each end of the cavity. Inspect the installed o-ring (items 22) for cuts and/or wear. Replace the o-rings if necessary. Apply a light coating of grease to each o-ring and re-install the plungers in to the bushings. Push the plungers in as far as they will go.

To remove the bushings (item 7), first remove the retaining rings (item 26) by using a flat screwdriver. **NOTE:** It is recommended that new retaining rings be installed.

Step #3: Re-install the pilot valve assembly into the intermediate assembly.

Be careful to align the ends of the stem between the plungers when inserting the stem of the pilot valve into the cavity of the intermediate.

Re-install the gasket (item 18), air inlet cap (item 8) and capscrews (item 11).

Connect the air supply to the pump. The pump is now ready for operation.

ACTUATOR PLUNGER SERVICING

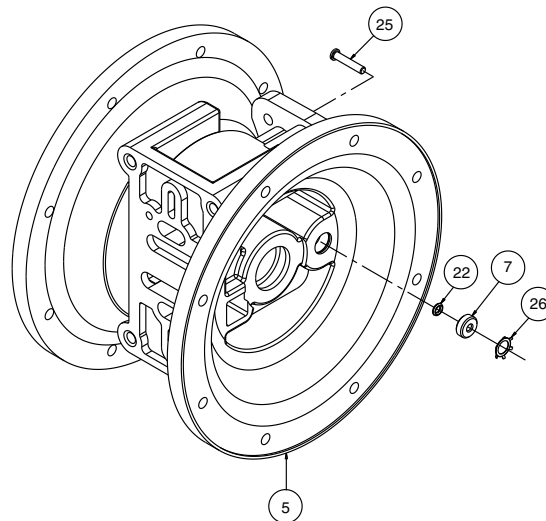

! IMPORTANT

Read these instructions completely, before installation and start-up. It is the responsibility of the purchaser to retain this manual for reference. Failure to comply with the recommendations stated in this manual will damage the pump, and void factory warranty.

CHECK VALVE SERVICING

Before servicing the check valve components, first shut off the suction line and then the discharge line to the pump. Next, shut off the compressed air supply, bleed air pressure from the pump, and disconnect the air supply line from the pump. Drain any remaining fluid from the pump. The pump can now be removed for service.

To access the check valve components, remove the manifold (item 20 or item 19 not shown). Use a 1/2" wrench or socket to remove the fasteners. Once the manifold is removed, the check valve components can be seen.

Inspect the check balls (items 2) for wear, abrasion, or cuts on the spherical surface. The check valve seats (item 30) should be inspected for cuts, abrasive wear, or embedded material on the surfaces of both the external and internal chambers. The spherical surface of the check balls must seat flush to the surface of the check valve seats for the pump to operate to peak efficiency. Replace any worn or damaged parts as necessary.

Re-assemble the check valve components. The seat should fit into the counter bore of the outer chamber.

The pump can now be reassembled.

Check Valve Drawing

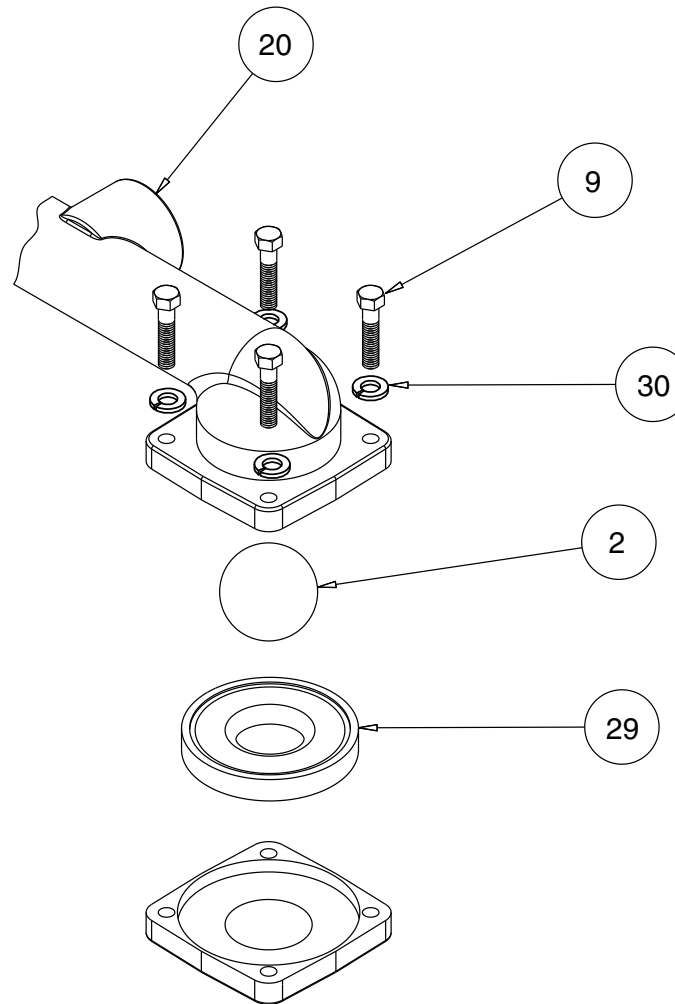

PUMPING HAZARDOUS LIQUIDS

When a diaphragm fails, the pumped liquid or fumes enter the air end of the pump. Fumes are exhausted into the surrounding environment. When pumping hazardous or toxic materials, the exhaust air must be piped to an appropriate area for safe disposal. See illustration #1 at right.

This pump can be submerged if the pump materials of construction are compatible with the liquid being pumped. The air exhaust must be piped above the liquid level. See illustration #2 at right. Piping used for the air exhaust must not be smaller than 1" (2.54 cm) diameter. Reducing the pipe size will restrict air flow and reduce pump performance. When the pumped product source is at a higher level than the pump (flooded suction condition), pipe the exhaust higher than the product source to prevent siphoning spills. See illustration #3 at right.

CONVERTING THE PUMP FOR PIPING THE EXHAUST AIR

The following steps are necessary to convert the pump to pipe the exhaust air away from the pump.

Remove the muffler (item 21). The air distribution valve (item 1) has 1" NPT threads for piped exhaust.

IMPORTANT INSTALLATION

NOTE: The manufacturer recommends installing a flexible conductive hose or connection between the pump and any rigid plumbing. This reduces stresses on the molded threads of the air exhaust port. Failure to do so may result in damage to the air distribution valve body.

Any piping or hose connected to the pump's air exhaust port must be conductive and physically supported. Failure to support these connections could also result in damage to the air distribution valve body.

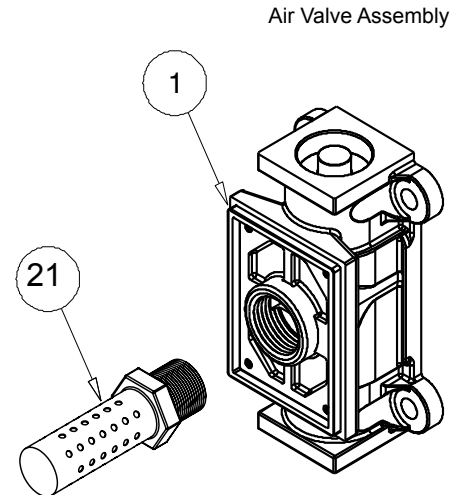

The pump comes equipped with a standard metal muffler

CONVERTED EXHAUST ILLUSTRATION

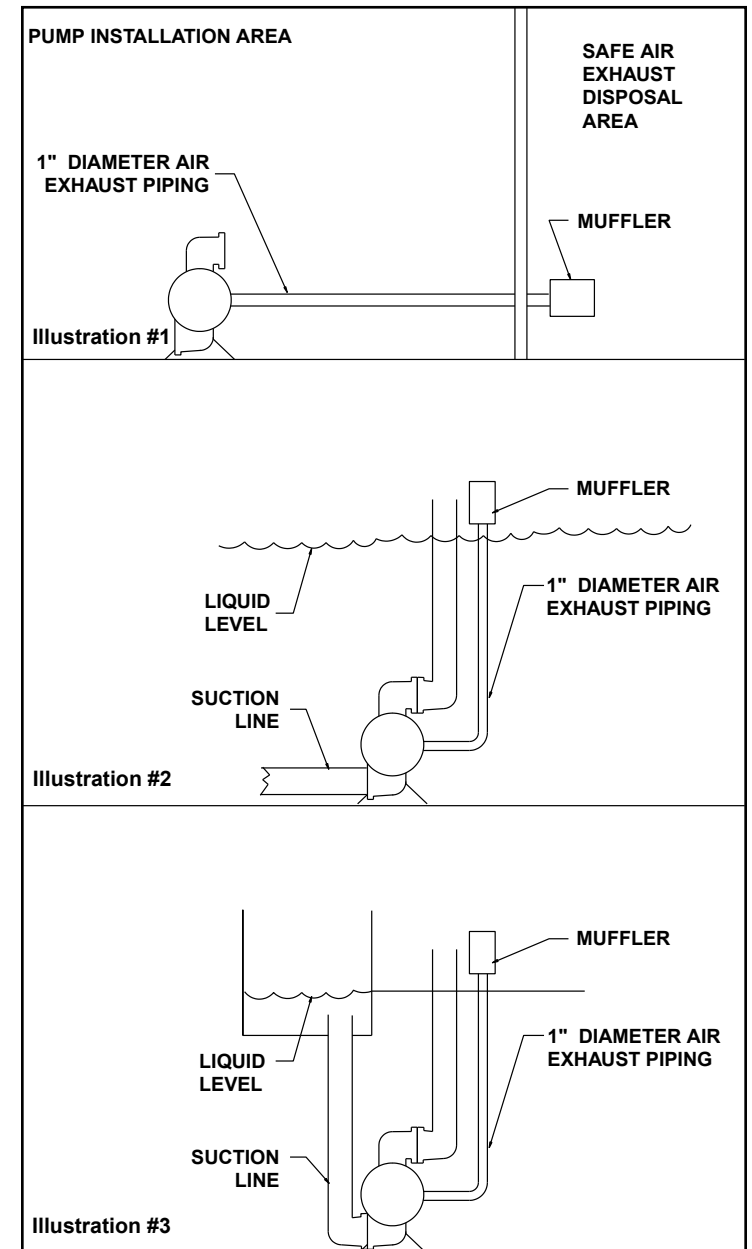

Grounding The Pump

One eyelet is fastened to the pump hardware.

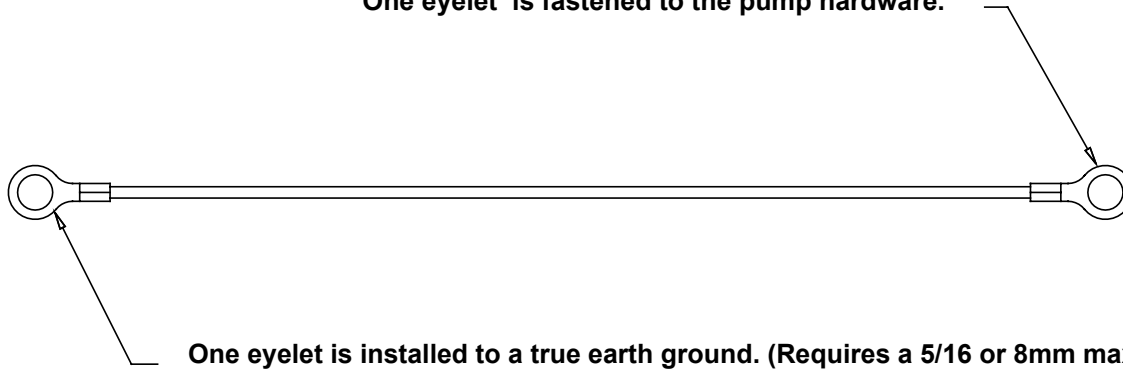

This 8 foot long (244 centimeters) Ground Strap (Item 32) is shipped with the eyelet end fastened to the pump hardware.

To reduce the risk of static electrical sparking, this pump must be grounded. Check the local electrical code for detailed grounding instruction and the type of equipment required, or in the absence of local codes, an industry or nationally recognized code having jurisdiction over specific installations and installation codes.

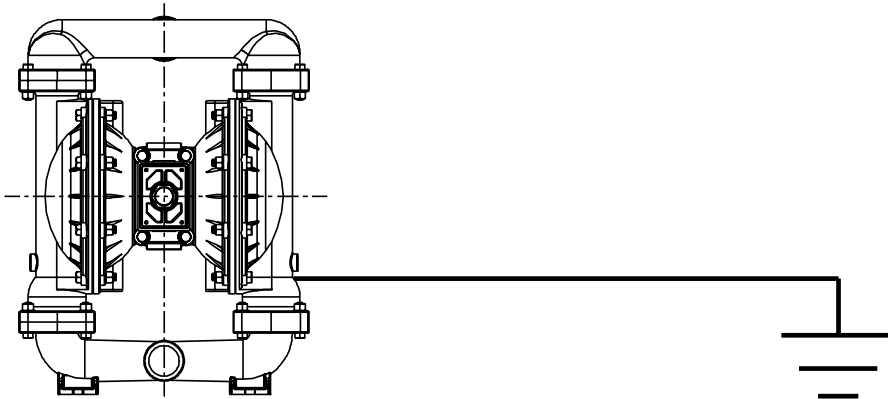

	! WARNING
	<i>Take action to prevent static sparking. Fire or explosion can result, especially when handling flammable liquids. The pump, piping, valves, containers or other miscellaneous equipment must be grounded.</i>

For Warranty Information Visit:
www.balcrank.com

Balcrank Corporation
115 Reems Creek Road
Weaverville, NC 28787
800-747-5300
800-763-0840 Fax
[**www.balcrank.com**](http://www.balcrank.com)

Distributed by:

SERVICE BULLETIN SB1113
Revised 11/11